

*JULY 4-8 WPQHA 4th OF JULY*

*Summer Circuit Celebration at The WPQHA Show Complex in Harlansburg, PA*

Approved by AQHA, WPQHA, TSQHA, PQHA, NSBA  
6 AQHA Shows Split/ Combined Shows in Five Days  
6 Judges TWO NSBA Shows



*Summer Circuit Celebration at The WPQHA Show Complex  
Harlansburg, PA Presents*

*JULY 4-8 Back to Back Three Judge Paint-O-Ramas*

Approved By: APHA, PPHC, NSBA



Judges: John Boxell, Randy Alderson, Tessa Sullivan,  
Gigi Bailey, April Devitt, Tom Mc Beath



# Pattern Book

**July 4,5,6, 2018**

# Showmanship (Level 1. 13-under.)

Show Date: 07-05-2018

W W W . H O R S E S H O W P A T T E R N S . C O M

W W W . H O R S E S H O W P A T T E R N S . C O M

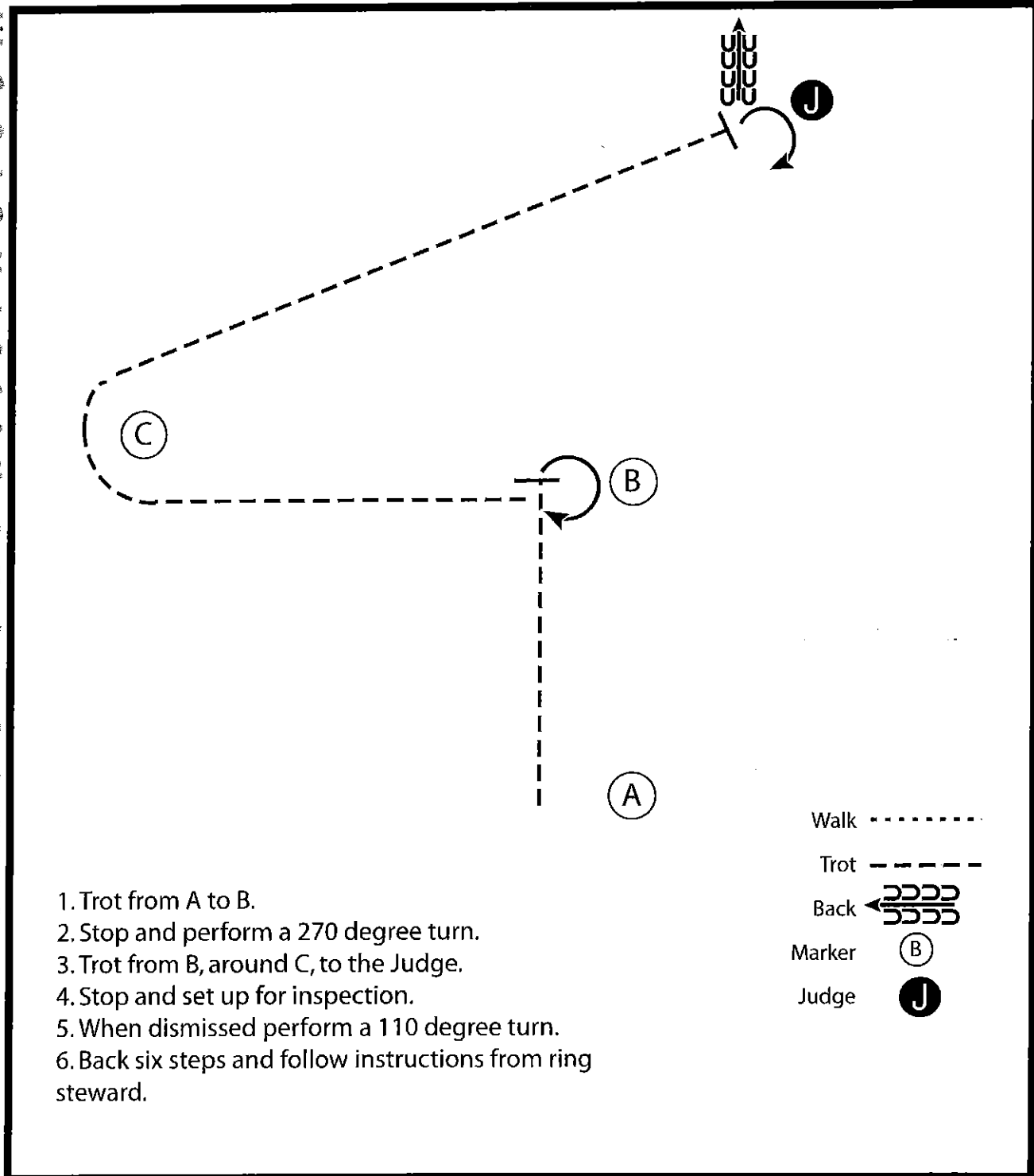

[S/2-11]

Pattern Provided by:

# Showmanship (Am, youth)

Show Date: 07-05-2018

*Paint Showmanship Am Youth*

www.HorseShowPatterns.com

www.HorseShowPatterns.com

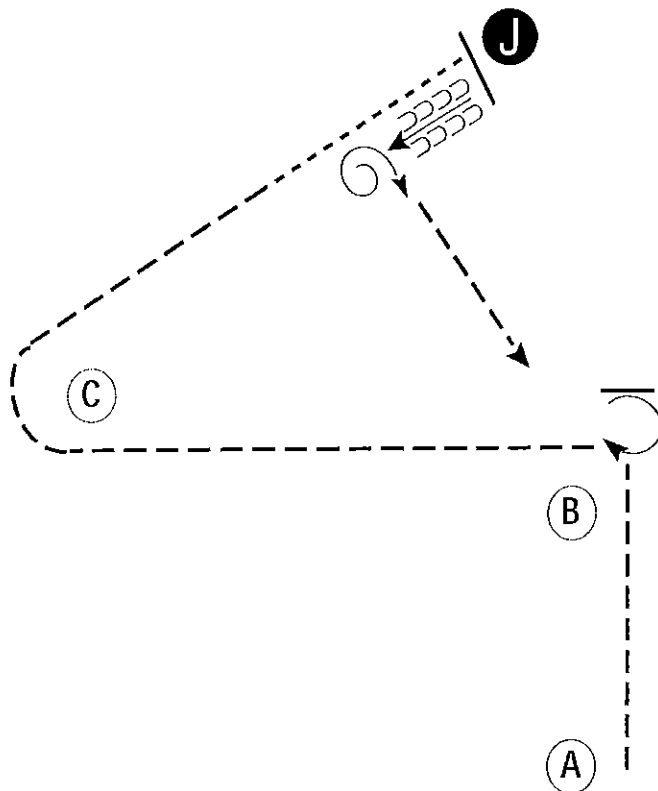

Be ready at A.

1. Trot from A past B.
2. Stop and perform 270 degree turn.
3. Trot around C. Break to a walk half way to the Judge.
4. Walk to Judge, stop and set up for inspection.
5. When dismissed back one horse length.
6. Perform a 450 degree turn and trot to the line-up or follow the instructions of your ring steward.

Walk	-----
Trot	- - - - -
Back	←
Marker	ⓑ
Judge	ⓐ

[S/3-14]

Pattern Provided by:

# Western Pa QH

Hunt Seat Equitation (Novice, youth, amt, )

Show Date: 07-04-2018

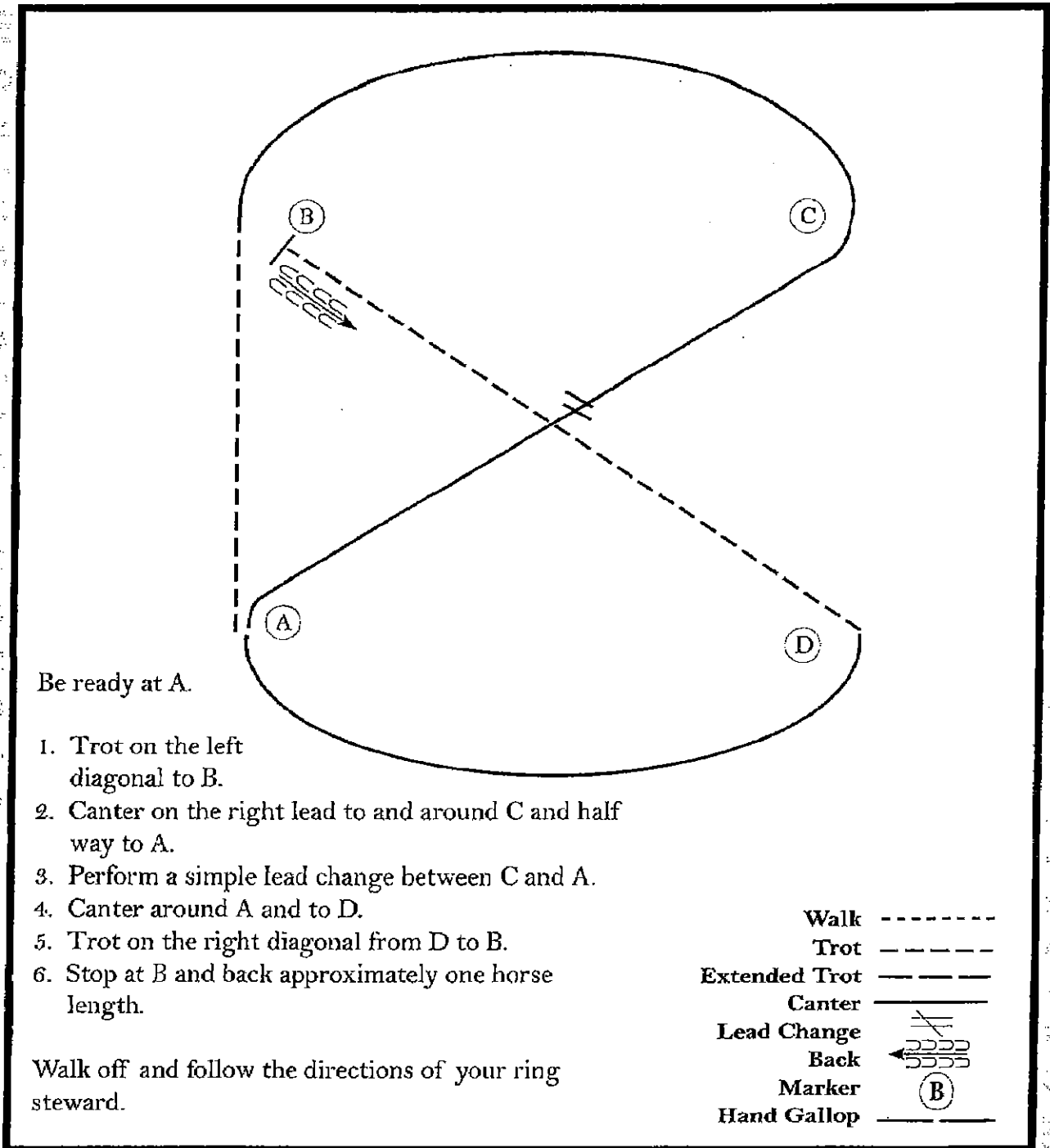

[HSE/1-52]

Pattern Provided by:

# Western Pa QH

## Hunt Seat Equitation (Amt, select, 14-18 youth)

Show Date: 07-04-2018

*Paint Equitation Ama + Youth*

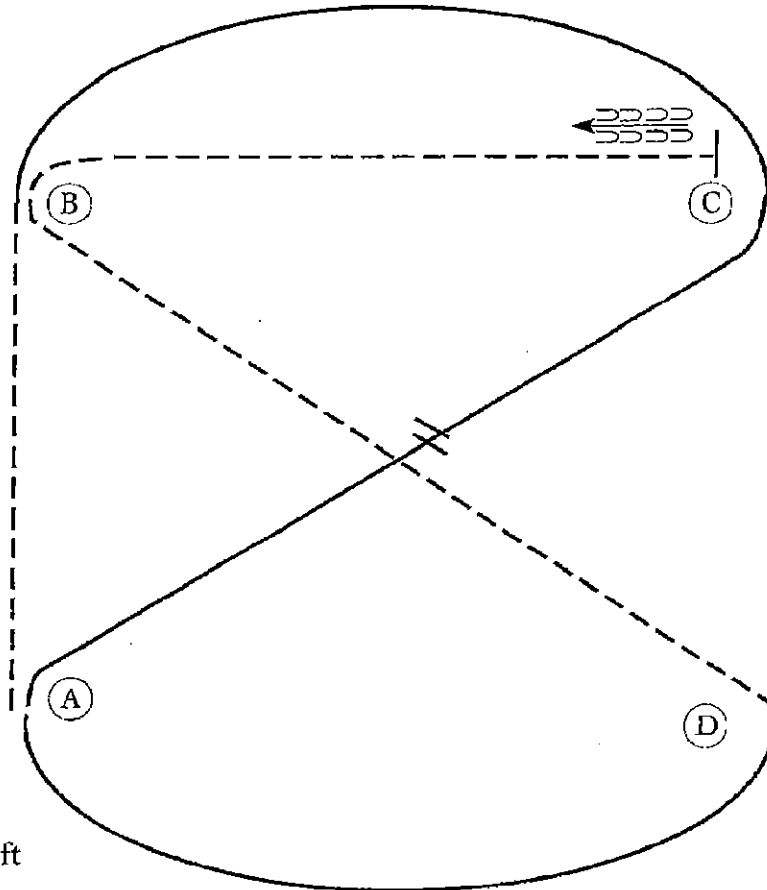

Be ready at A.

1. Trot on the left diagonal to B.
2. Canter on the right lead to and around C and half way to A.
4. Change leads between C and A.
5. Canter around A and to D.
6. Trot on the right diagonal from D to B.
7. Trot in a two-point position to C.
8. Stop at C and back approximately one horse length.

Walk off and follow the directions of your ring steward.

Walk	-----
Trot	- - - - -
Extended Trot	=====
Canter	—————
Lead Change	
Back	
Marker	(B)
Hand Gallop	—————

[HSE/2-52]

**Pattern Provided by:**

# Western Pa QH

Western Horsemanship (Novice youth , amt )

Show Date: 07-04-2018

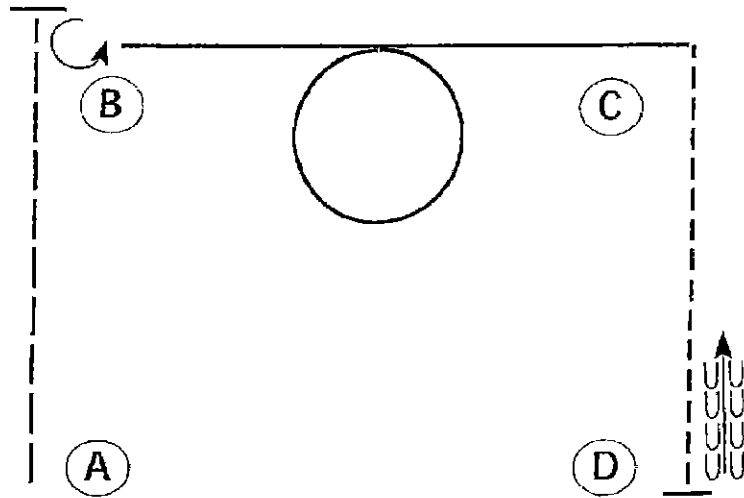

Be ready at A.

1. Extended trot from A past B.
2. Stop past B and perform a 270 degree turn to the left.
3. Lope on the right lead halfway to C.
4. Perform a small, slow circle to the right.
5. Continue to lope past C.
6. Jog to D.
7. Stop and back approximately one horse length.

Follow the instructions of your ring steward.

Walk	-----
Jog	-----
Extended Jog	-----
Lope	-----
Lead Change	
Back	
Marker	(B)

[WH/1-89]

Pattern Provided by:

# Western Pa QH

Western Horsemanship (Amt, select, 14-18)

Show Date: 07-04-2018

*Paint Horsemanship AMA & Youth*

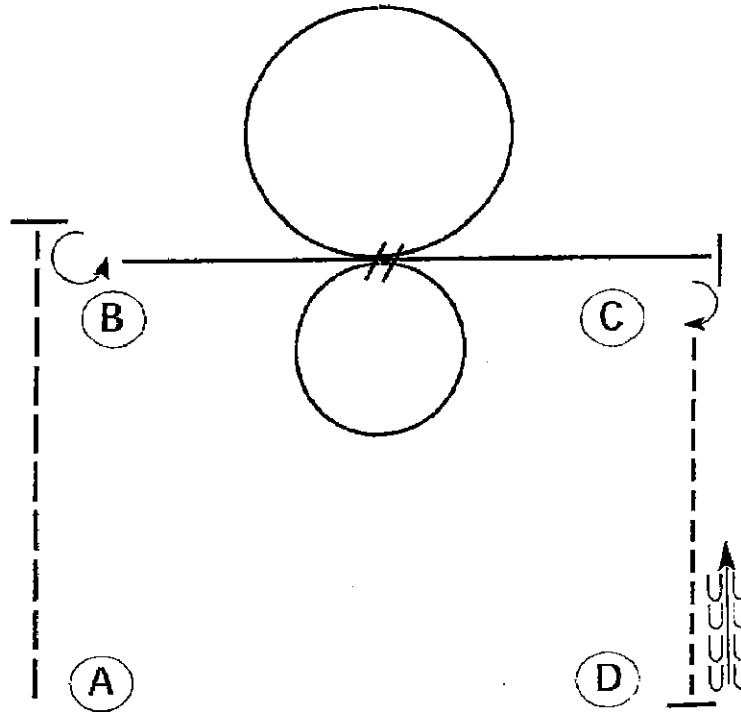

Be ready at A.

1. Extended trot from A past B.
2. Stop past B and perform a 270 degree turn to the left.
3. Lope on the right lead halfway to C.
4. Perform a small, slow circle to the right.
5. Change leads and perform a large, fast circle to the left.
6. Continue to lope past C and stop.
7. Perform a 1/4 turn to the right.
8. Jog to D.
9. Stop and back approximately one horse length.

Follow the instructions of your ring steward.

Walk	-----
Jog	-----
Extended Jog	-----
Lope	-----
Lead Change	
Back	
Marker	(B)

[WH/2-88]

Pattern Provided by:

# Western Pa QH

## Ranch Riding

Show Date: 07-04-2018

www.horsecorner.com

www.horsecorner.com

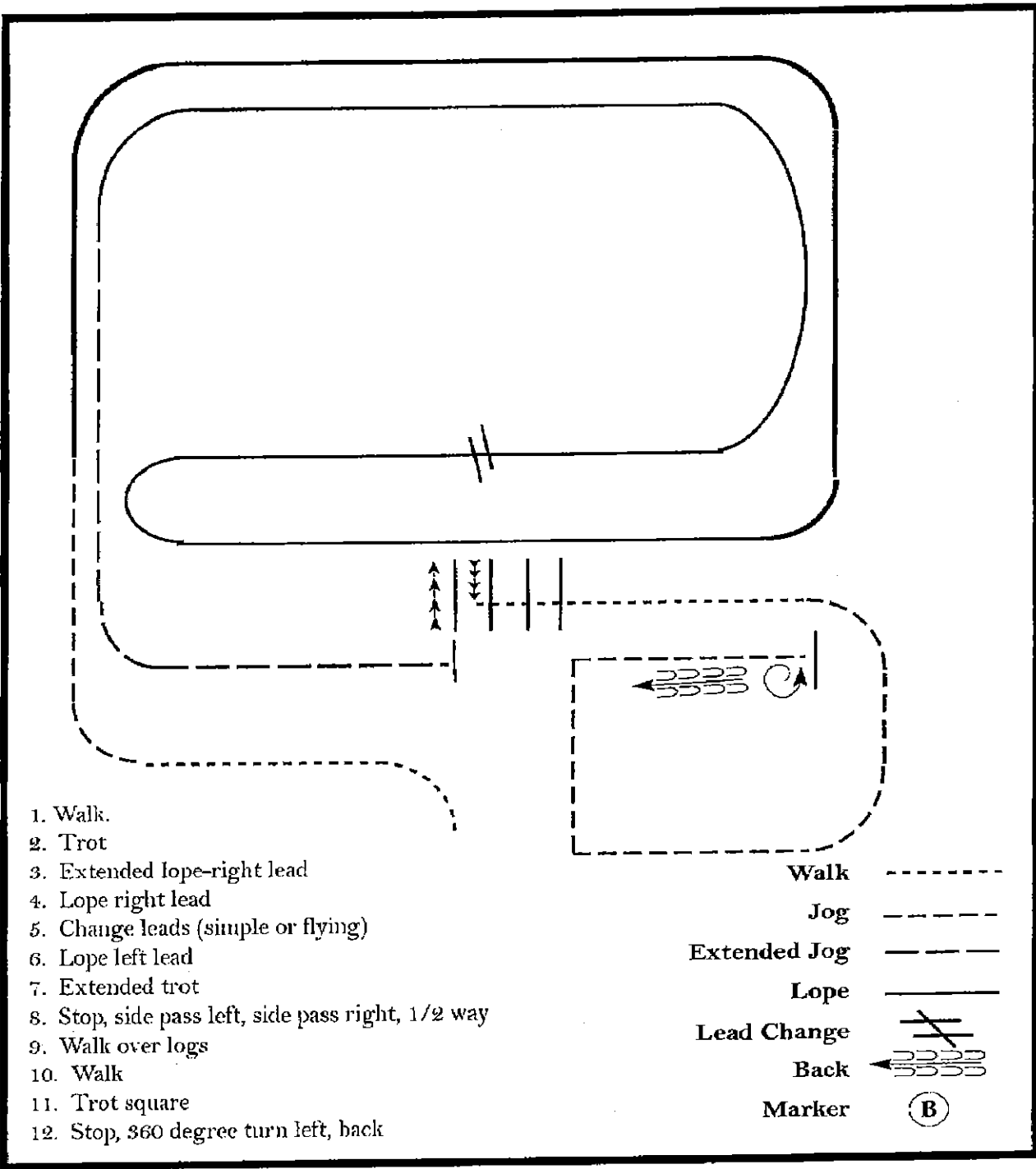

1. Walk.
2. Trot
3. Extended lope-right lead
4. Lope right lead
5. Change leads (simple or flying)
6. Lope left lead
7. Extended trot
8. Stop, side pass left, side pass right, 1/2 way
9. Walk over logs
10. Walk
11. Trot square
12. Stop, 360 degree turn left, back

- Walk
- Jog
- Extended Jog
- Lope
- Lead Change
- Back
- Marker

[RR/5]

Pattern Provided by:



# Western Riding (All)

Show Date: 07-05-2018

www.HorseShowPatterns.com

www.HorseShowPatterns.com

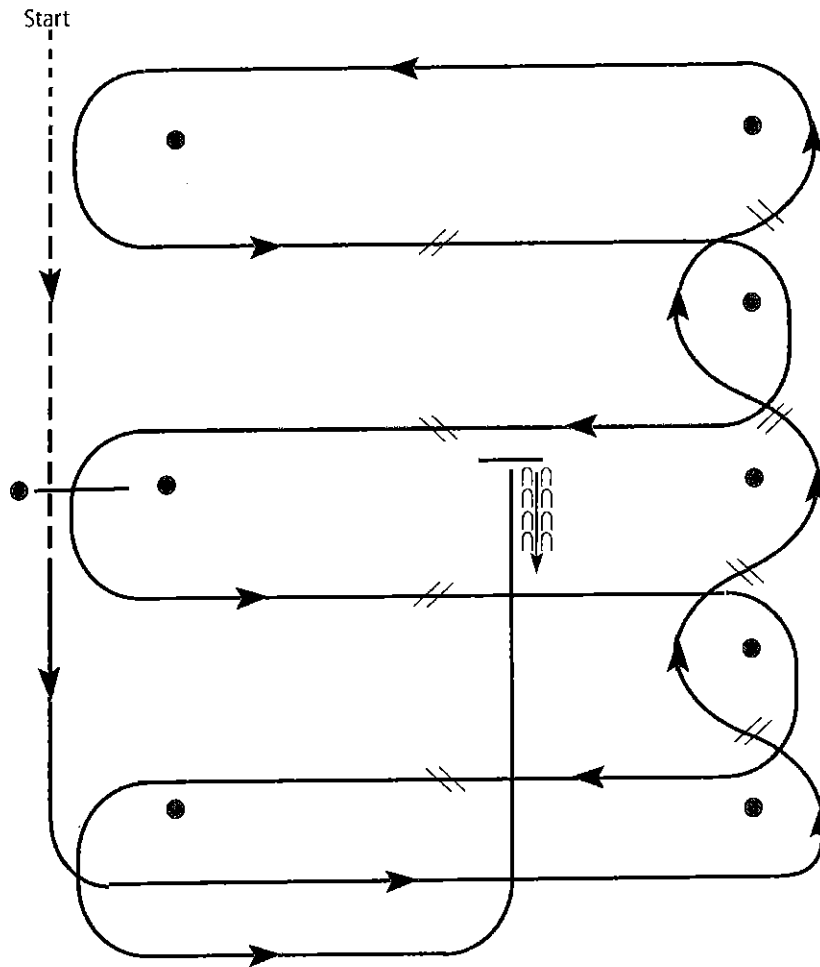

1. Walk and jog over log.
2. Transition to lope and lope around end.
3. First line change.
4. Second line change.
5. Third line change.
6. Fourth line change and lope around the end of the arena.
7. First crossing change.
8. Second crossing change.
9. Lope over log.
10. Third crossing change.
11. Fourth crossing change.
12. Lope up the center, stop and back.

[WR/OP-1]

Pattern Provided by:



ALL TRAIL  
EXCEPT WALK → TROT

④  
RIGHT  
HAND  
GATE

⑤ LOPE POLES  
RIGHT LEAD  
AROUND CORNER &  
OVER POLES  
AGAIN

⑥  
TROT  
POLES

③  
TROT  
SERPENTINE  
UP TO  
GATE

⑦ LOPE  
TRIANGLE  
LEFT LEAD

⑧ TROT  
TRIANGLE &  
INTO BOX

⑨ STOP IN BOX  
360 TO LEFT  
WALK OUT

②  
WALK  
POLES

①  
BACK "L"

START

FINISH

CIRCUIT  
SHOW

